

TB-45 NON POWER FAILURE 24 HOURS TIME SWITCH

NEW

FEATURES

- Back up Battery For 100 Hours When Power Failure (just for clock running not for output on/off switching)
- 15-Minute-Interval, 24 Hours Dial With Built In Time Set Pins.
- HANDY \odot /I SELECT SWITCH
 \odot : 24H PROGRAM AUTO CONTROL
 I : PERMANENT CONTROL ON

SPECIFICATIONS

Model No.	TB-45
Movement Type	AC Type
Rated Voltage	110-250V
Frequency	45-60Hz
Movement	Quartz
Back up Power	100 Hours
Resistive Load	250V AC 16A
Lamp Load	2A
Inductive Load	10A(cos ϕ = 0.7 or more)
Motor Load	4A
Minimum Setting Unit	15 minute units
Minimum Setting Interval	15 minute
No. of ON-OFF Operations	96 operations



TB-45

WIRING CONNECTION DIAGRAM

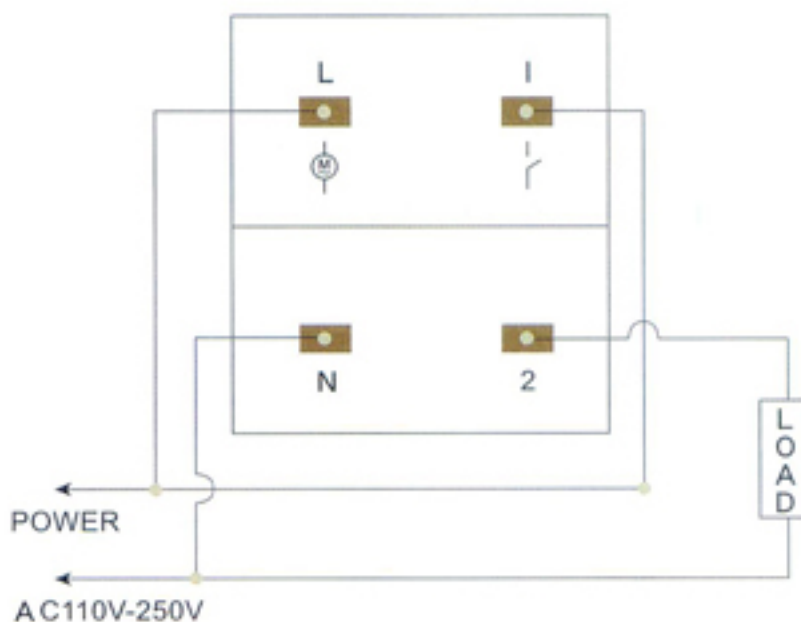

CAUTIONS

1. For the first time, please charge battery first for 10 minutes before use.
2. To set the correct time, turn the dial in the direction of the arrow and set the present time.
3. Please observe the rated voltage and voltage tolerance of the time switches for adequate use.
4. Do not use the time switch where:
 - there is much dust
 - there is much moisture
 - outdoors or where it will be exposed to rain or water
 - there is much vibration
5. When the time switch is used for loads exceeding the rated capacity, it is imperative that the time switch be used in combination with one or more magnetic contactors according to each load.
6. Mounting methods : BY DIN RAIL (35mm)