

TECHNICAL DATA

- Item No.: TH-192
- Operation Voltage: 110-240V AC
- Frequency: 50/60Hz
- Resistive Load: 16A/250V AC
- Ambient Temperature: -10°C ~ +60°C
- Battery Backup: 60 days
- Minimum Programmable time: 1 Minute
- Maximum Programmes: 17 ON + 17 OFF
- Mounting Methods: By din rail (35 mm)
- 15 Combination of daily-programs:

| | | | | | | | |
|-----|----|----|----|----|----|----|----|
| 1. | MO | TU | WE | TH | FR | SA | SU |
| 2. | MO | TU | WE | TH | FR | SA | |
| 3. | MO | TU | WE | TH | FR | | |
| 4. | | | | | | SA | SU |
| 5. | MO | | WE | | FR | | |
| 6. | | TU | | TH | | SA | |
| 7. | MO | TU | WE | | | | |
| 8. | | | | TH | FR | SA | |
| 9. | MO | | | | | | |
| 10. | | TU | | | | | |
| 11. | | | WE | | | | |
| 12. | | | | TH | | | |
| 13. | | | | | FR | | |
| 14. | | | | | | SA | |
| 15. | | | | | | | SU |



DIMENSIONS (mm)

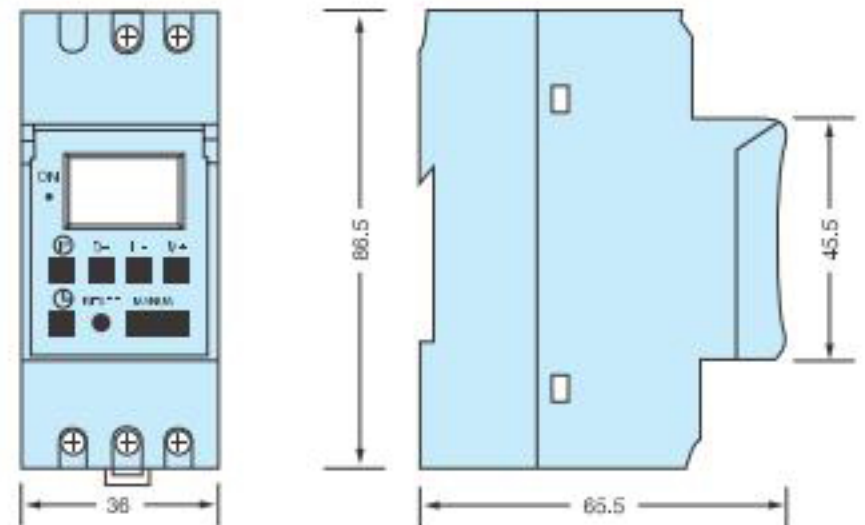

WIRING CONNECTION DIAGRAM

When the time switch is used for loads exceeding the rated capacity, it is imperative that time switch be used in combination with one or more magnetic contactors according to each load.

• FOR LIGHT LOAD

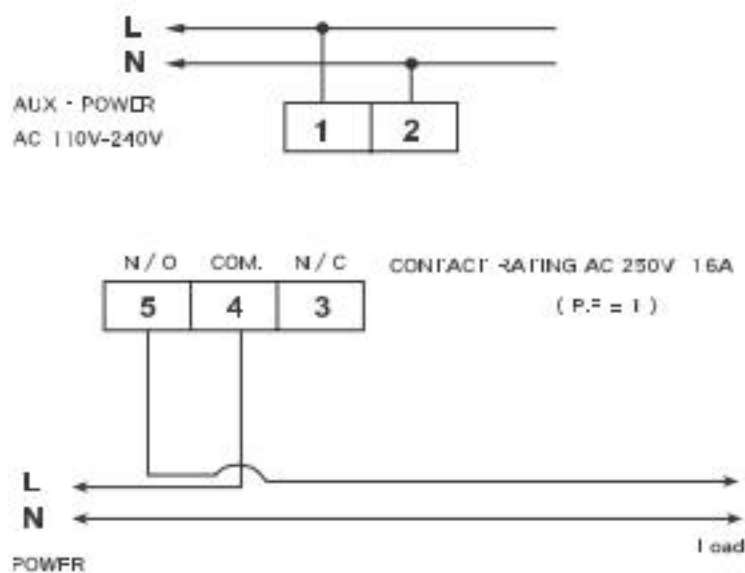

• FOR HEAVY LOAD

